

# Foreword

Welcome you to purchase our products and become our customers.

This manual describes MPS4 simple organic glass diamond polishing machine you select. The machine is suitable for polishing various types of organic glass, and has a compact structure and high degree of automation, being an economical automatic processing equipment. It is equipped with a variable frequency electric spindle, a Taiwan gear motor and a stable logic control circuit, greatly improving the reliability of equipment operation. The button control makes operation easier and more flexible. In addition, it is also suitable for polishing materials with certain angles, achieving multiple purposes and greatly saving the one-time capital investment of the user and being an ideal equipment for polishing organic glass at low cost.

# Table of Contents

Chapter I Equipment Characteristics and Performance Parameters.....	1
1.1 Equipment Characteristics.....	1
1.2 Main Technical Specifications.....	2
Chapter II Equipment Handling.....	3
2.1 Unpacking.....	3
2.2 Equipment Handling.....	3
Chapter III Installation.....	4
3.1 Installation Site and Environment.....	4
3.2 Level Adjustment of Equipment.....	4
Chapter IV Equipment Commissioning.....	5
4.1 Preparations.....	5
4.2 Power-on Commissioning.....	6
(1) Spindle system.....	7
(2) Feed system.....	7
(3) Spindle moving system.....	7
(4) Pneumatic system.....	7
4.3 Equipment Operation Requirements and Precautions.....	8
Chapter V Equipment Structure.....	9
5.1 Equipment Effect Picture.....	9
5.2 Spindle Moving Device.....	11
5.3 Positioning Pressure Device.....	13
Chapter VI Equipment Operation.....	15
6.1 Introduction to Operation Panel.....	15
6.2 Understanding, Installation and Adjustment of Spindle Total Bearing/Tool Pan/Tool.....	16
6.2.1 Understanding of Spindle Total Bearing.....	16
6.2.2 Understanding of Tool Pan.....	17
6.2.3 Tool.....	17
6.2.4 Tool Installation and Adjustment.....	18
Chapter VII Equipment Operating Procedure.....	21
7.1 Main Electrical Components.....	21
7.2 Operating Procedure.....	22
7.2.1 Operating Procedure Before Running.....	22
7.2.2 Tool Setting Procedure.....	23
7.2.3 Running Procedure.....	24
Chapter VIII Common Faults and Equipment Maintenance.....	25
8.1 Common Faults.....	25
8.2 Equipment Maintenance.....	25

# **Chapter I Equipment Characteristics and Performance**

## **Parameters**

### **1.1 Equipment Characteristics**

MPS4 steel structure diamond polishing machine is a simple product recommended to the user to meet the market requirements. It has excellent performance, high cost performance and stable structure. The machine layout is compact and reasonable, its high speed, high precision and high rigidity provide the users with high efficiency and high reliability in use.

The feed system of the machine uses racks for driving, its good rigidity and dynamic behaviour greatly improve the movement and positioning, increase the wear resistance of the moving parts and enhance the impact resistance, so that the entire machine can keep the precision of guide rail for a long time, and the service life of the equipment can be improved.

The machine can be optionally equipped with a dust exhaust apparatus, which can reduce the labor intensity of the operator and realize safe and efficient production.

The machine uses a semi-closed sheet metal protective cover, which adopts the firm and reliable design for the safety and convenience of users.

Our strict quality system and high quality after-sales service will provide all guarantee for our customers.

## 1.2 Main Technical Specifications

Model	MPS4
Overall dimensions (except foundation)	2055*1150*1530mm
Processing range	110 (T)*1300 or infinite length
Machine power	2.7KW
Main motor power	1.5KW
Main motor speed	7000 ~ 9000rpm
Speed adjustment mode	Frequency control
Feed speed	0 ~ 2000mm / min ( 0 ~ 30HZ )
Tilt angle	0 ~ 60°
Operating voltage	AC50 ~ 60HZ,3ph220v
System air pressure	0.6 ~ 0.8Mpa

## **Chapter II Equipment Handling**

### **2.1 Unpacking**

The rainproof packaging is used for the equipment or the equipment is boxed, the key parts and components are coated with anti-rust oil, and vibration and impact resistant measures are taken to ensure safe transportation and storage within 25-55 °C. However, the equipment shall not be placed upside down or tilted for more than 15° during the transportation, and violent impact and vibration is not allowed so as to avoid damage to internal components. The user should open the packing box for inspection as soon as possible after receiving the equipment. During the inspection, special attention should be paid to the following items:

- a. Inspect whether the whole packaging is complete.
- b. Inspect whether the equipment is affected with damp during transportation.
- c. Inspect whether the equipment appearance and components are damaged during transportation.
- d. Check according to the list provided in the toolbox to see if there are any inconsistencies.

If you find any problem when unpacking, please contact our factory and the carrier of the equipment as soon as possible to solve the problem.

### **2.2 Equipment Handling**

It is recommended not to transport the equipment and adjust the installation position by means of lifting. It is better to transport by forklift. When the equipment is hoisted, special care should be taken to prevent equipment control system, electrical components, etc. from being impacted and collided. Before hoisting, inspect whether all parts of the equipment are fixed and whether there are no moving parts. Some accessories and objects that do not belong to the equipment should be removed. The equipment must be hoisted with the wire rope. The wire rope shall not be seriously squeezed or come into contact with the equipment, and the equipment impact and vibration shall be minimized. The packing box of the equipment shall not

be placed on the angular object or upside down to avoid affecting the precision of the equipment. When unpacking, firstly inspect the external condition of the equipment, and check accessories and tools according to the packing list. To keep the hoisted equipment or packing box balanced in all directions, appropriate adjustment shall be made as soon as it is lifted off the ground. The angle between the hoisting wire ropes shall not be more than 60 degrees. If equipment hoisting is operated by several persons, they shall coordinate.

The same precautions shall be followed when the equipment is transported by forklift. The forklift shall be slowed down as much as possible to avoid being out of control due to the inertia during the rapid start and stop. The forklift driver shall be trained and qualified, shall be careful not to hurt the cooperative operators, not to knock against the equipment and not to tilt the equipment excessively. Special attention shall be paid during lifting and unloading, and the equipment shall not be subjected to shock and violent vibration.

## **Chapter III Installation**

### **3.1 Installation Site and Environment**

The equipment installation site must meet the following conditions:

- a. Dry, ventilated site
- b. Site free of inflammable and corrosive liquid and gases
- c. Site free of high impact and shock
- d. Site away from loud noise source
- e. Installed on the flat cement floor

### **3.2 Level Adjustment of Equipment**

The user shall make the level adjustment of the equipment after the equipment is in place, because level is the the initial benchmark for all precision of the whole machine. The final machining precision of the equipment can be guaranteed only if

the level adjustment is completed. The user can adjust the equipment level according to the following steps.

- a. Adjust foundation bolts one by one, so that the bolts are stressed uniformly when the equipment has no obvious bias.
- b. Place the plumb level on the table.
- c. The horizontal and vertical travels can be equally divided into front, middle and rear observation points.
- d. Adjust the foundation bolts one by one according to the readings of the plumb level.
- e. Repeat the above steps till the level readings meet the requirements.
- f. Lock all foundation bolts.

## Chapter IV Equipment Commissioning

### 4.1 Preparations

The following work shall be completed before commissioning:

- a. Completely remove the anti-rust oil from the equipment.
- b. Determine that all bolts of the equipment have been fastened.
- c. Determine that the oiler of the equipment has been filled with lubricating oil.
- d. Determine that the fixing device of the equipment has been removed.

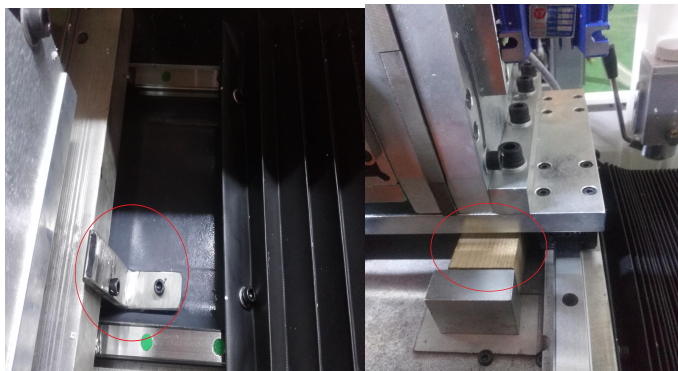

Before the machine is powered on, please remove the locking block installed on the machine and located on the side of the spindle moving device, and the spindle

antedisplacement limit fixing block.

## 4.2 Power-on Commissioning

After the equipment is powered on, the following items shall be inspected one by one:

- a. Inspect whether the electrical components are normal

Power supply requirements: standard three-phase four-wire 380V/20A, three-phase 220V and single-phase 220V for special power distribution, good grounding and zero line, connection mode as shown in the right figure, located in the electric cabinet, use ground wire not less than 1.5 mm<sup>2</sup> to connect the casing.



- b. Inspect whether the oil circuit is smooth and whether there is oil leakage.
- c. Inspect whether the pneumatic component is normal.

Compressed air: the minimum pressure shall be 0.5Mpa, otherwise the machine will given an alarm and stop operating. The inlet pipe connection is shown in the right figure. The air source inlet shall be 10mm air pipe. Adjusting method of pressure adjusting knob:

Lift the adjusting knob up, turn clockwise to increase the barometric pressure, and turn

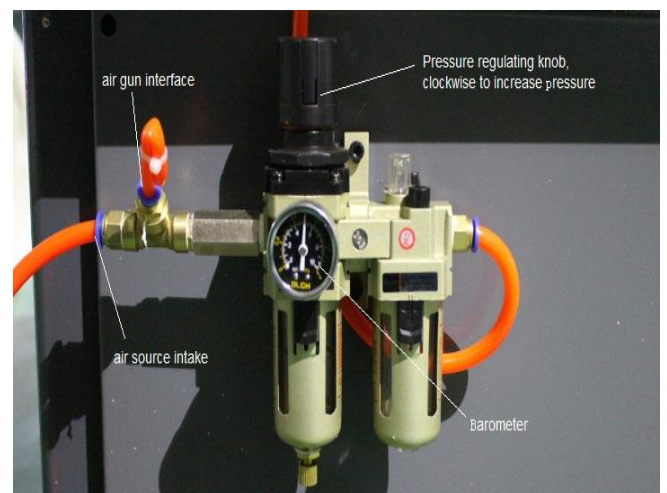

counterclockwise to decrease the barometric pressure. The components can be commissioned when determining that above items are normal.

### **(1) Spindle system**

If the downtime is more than ten days, the spindle should complete operation from low speed to high speed. It is recommended that the user should operate the spindle at 20% of the highest equipment speed as the primary speed, and then increase by 20% of the highest equipment speed till the highest equipment speed. The operating time at each speed shall not be less than 30 minutes. If the spindle rotates counterclockwise, i.e. in reverse direction, please contact our technician.

### **(2) Feed system**

In the normal operation of the lubrication system for the equipment, move the supporting plate in the manual mode, and inspect whether the lateral movement of the feed system is smooth and whether the limits are effective.

### **(3) Spindle moving system**

After confirming that all tools are installed correctly on the spindle tool pan, inspect whether they will interfere with the equipment tabletop, and adjust the throttle valve of the cylinder to control the moving speed.

### **(4) Pneumatic system**

Principle of pneumatic system

The pneumatic system is composed of F.R.L, a solenoid directional valve, a check valve and a silencer. F.R.L is installed at the position easy to observe, and other components are installed at the necessary positions. F.R.L has the functions of

filter, reducing valve and lubricator. See the manual for F.R.L for the specific adjustment modes.

The solenoid directional valve is mainly used to control the direction of the air passage to complete the actions of clamping and loosening. The check valve has the function of pressure maintaining to avoid the disturbance caused by the unstable gas source at the far end. When the cylinder moves, air at the exhaust port is discharged directly by the silencer.

**Notes:**

a. The air source component oil shall be clean and replenished in time. The oil level shall not be too high for fear of losing the air pressure. When the nylon tube is cut off and inserted into the connector, the connector shall be deburred and smooth, and good sealing may be achieved. To remove the air pipe, press the blue plastic of the pipe fitting by your finger and then easily remove the air pipe. Do not force to pull out to avoid damaging the pipe fitting.

b. The pressure of air source shall be about 0.5MPa, and the capacity shall not cause significant pressure decrease when the equipment operates. It is recommended to use a slightly large air pressure station for air supply to ensure the stability of the pneumatic system.

c. Regularly clean the filter screen, water cup and oil cup of the air source component as the case may be.

### **4.3 Equipment Operation Requirements and Precautions**

Untrained personnel are not allowed to operate the machine. The instructions before operation are as follows:

1. Do not manually loosen the clamp and lift the positioning plate during the operation of the machine.

2. Workpiece clamping is an important link in the whole process of polishing. Unsmooth clamping will cause incomplete polishing. Therefore, the workpiece must be clamped close to the reference positioning plate during loading; unloading can be carried out only after the reference positioning plate is dropped, in order to avoid

accidental collision or injury.

3. Control the polishing feed speed within 1200mm. Do not place sundries on the loading platform to avoid accidental collision caused by falling into the working slot.

The content of the picture in this manual is not necessarily the same as that of the customer's model. The machine parameters vary with the models. They shall be set according to the actual situation.

## Chapter V Equipment Structure

### 5.1 Equipment Effect Picture





1. Positioning pressure device: positioning plate, which is the polishing benchmark. There are five clamps for the standard model. The clamps can be added. The position of clamps can be adjusted as required.
2. Spindle turnover device: fore and aft movement and angle turnover of spindle.
3. Electric cabinet: there are external input power terminal posts and machine power switch inside the electric cabinet.

## 5.2 Spindle Moving Device

To realize the fore and aft movement and motor angle turnover of the spindle.

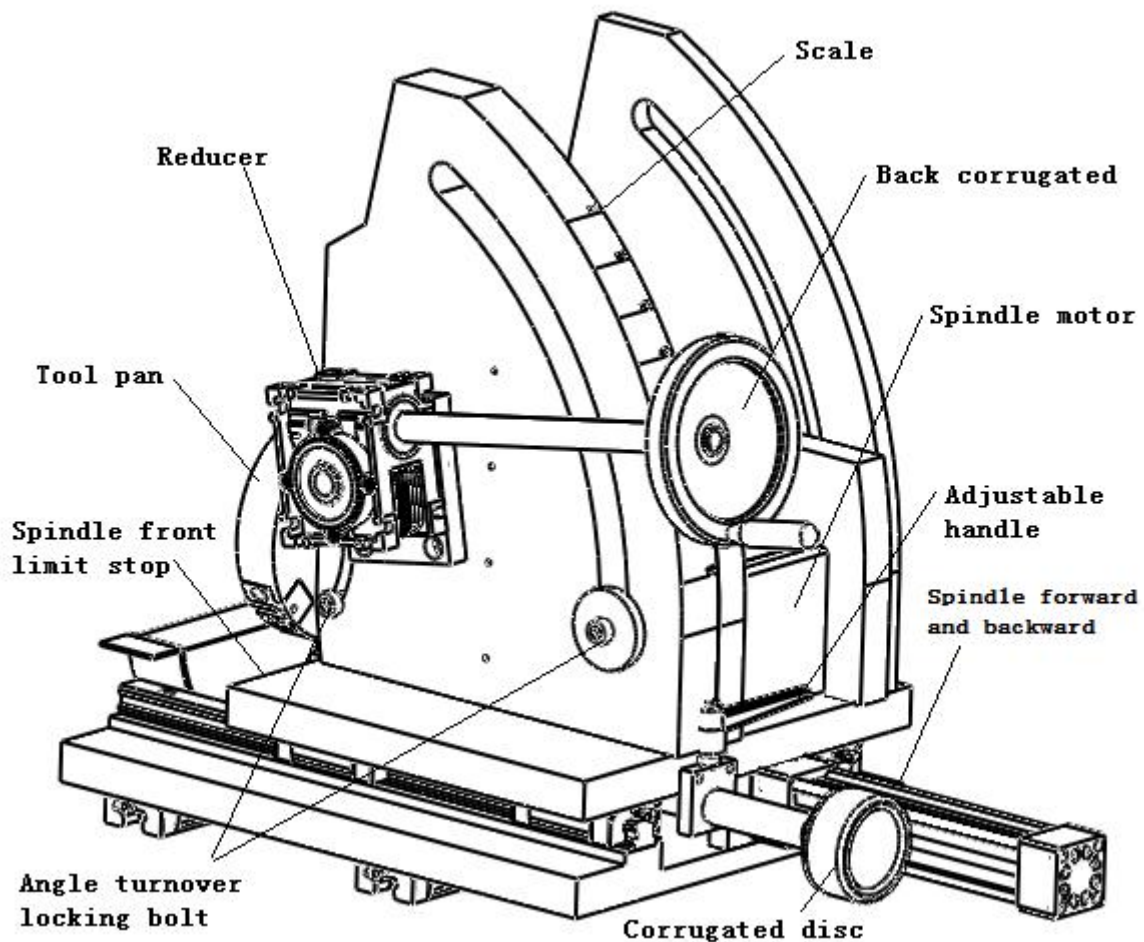

1. Spindle front limit stop: the cutting volume at the position of the limit stop is adjusted by the spindle limit setting knob, namely, the corrugated disc. The excessive forward adjustment will cause collision. Adjustment shall be made in combination with the spindle movement button.
2. Adjustable handle: for locking the spindle feed shaft.
3. Angle adjustment mechanism: the angle rotation is driven by the reducer and the

gear. The angle is increased by rotating the connected handwheel clockwise; the angle is decreased by rotating the connected handwheel counterclockwise. The settable angle of the machine is 0-60 degrees. Before adjustment, loosen the angle turnover locking bolt. When restoring to the level, lock the bolt to reduce vibration.

Adjustment method: when it is necessary to adjust the angle, firstly loosen the locking bolt, rotate the handwheel to the desired angle, then tighten the bolt, adjust the spindle limit stop, and set the cutting volume of the tool before starting work.

4. Angle turnover locking bolt: there are two angle turnover locking bolts on the left and right for fixing the spindle turnover.

5. Corrugated disc: spindle limit setting knob, which is connected to the spindle feed screw and located behind the spindle. Turn the corrugated disc by one circle, then the spindle limit stop moves by 1 MM; turn the corrugated disc by one division, then the spindle limit stop moves by 0.1 MM. Turn the corrugated disc clockwise, then the spindle limit stop advances; turn the corrugated disc counterclockwise, then the spindle limit stop retreats. Adjust this button to control the cutting volume.

6. Scale: engraved with 0°-60° for the convenient and rapid implementation of angle polishing.

**Note: the spindle limit positions are different in the level mode and the angle mode. The spindle limit position is near the front in the angle model. After restoring to the level model, adjust the spindle limit setting knob to move the spindle limit position backward to avoid collision.**

### 5.3 Positioning Pressure Device

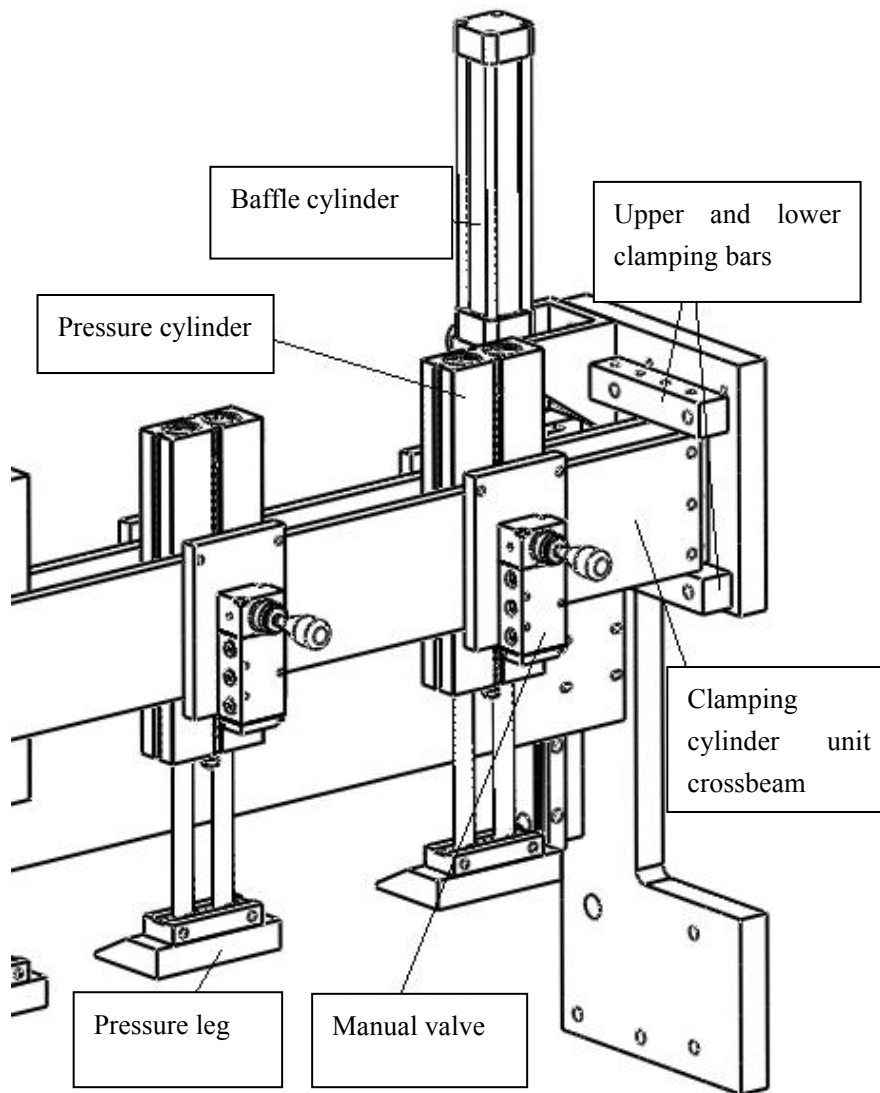

1. Manual valve: for controlling the lifting of pressure cylinder.
2. Baffle cylinder: for controlling the lifting of positioning plate cylinder.
3. Pressure leg: it can be removed and reassembled reversely to discharge smaller materials.
4. Upper and lower clamping bars: lock the bolt by clamping the cylinder unit

crossbeam, and move fore and aft after releasing the cylinder unit crossbeam.

#### Adjustment of cylinder speed

Step	Content
1	Stop the operation of equipment, and connect the air source.
2	Manually trigger the solenoid valve.
3	Press or release the trigger button on the solenoid valve to make the cylinder extend and retract, and visually measure the cylinder speed.
4	Turn the throttle valve adjustment button counterclockwise to slow down; turn the throttle valve adjustment button clockwise to speed up.
5	Repeated the steps 3-4 till the speed is suitable.

# Chapter VI Equipment Operation

## 6.1 Introduction to Operation Panel

- 1、 Power switch
- 2、 Touch screen
- 3、 Stop button
- 4、 Operation button
- 5、 Return button
- 6、 Scram button: An emergency power off



## Mintech Acrylic Polishing Machine



10 : 49

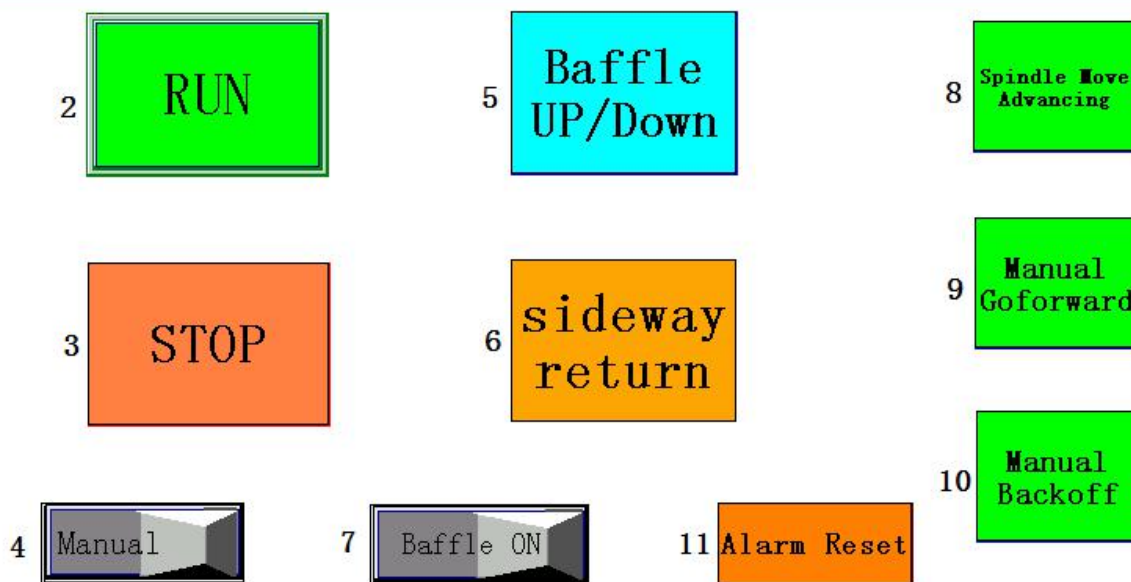

1. Alarm lamp: when the device gives an alarm (if the baffle is not in place), the alarm lamp is on. Press the alarm reset button to cancel the alarm.
2. Operation button: press this button, the machine starts running, and the polishing

process is started.

3. Stop button: press and hold this button, the machine stopped.

4. Manual/Auto conversion.

5. Baffle button: when the spindle turnover device is in the backward state, press the button, then the baffle falls; press the button again, then the baffle rises.

6. Return button: press and hold this button, Spindle back, touch induction switch or press stop button to stop.

### **7. Baffle ON/OFF**

8. Spindle movement button: when the baffle is in the rising state, press this button, then the spindle turnover device moves forward, and vice versa. **Note: before pressing this button, make sure that the spindle moving position will not collide with the working platform. If you do not know, adjust the spindle limit setting knob to make the spindle limit stop move backward to avoid collision.**

9. Manual forward button: press and hold this button, then the spindle turnover device moves horizontally, i.e. moves to the left.

10. Manual backward button: press and hold this button, then the spindle turnover device moves horizontally, i.e. moves to the right.

## **6.2 Understanding, Installation and Adjustment of Spindle Total Bearing/Tool Pan/Tool**

### **6.2.1 Understanding of Spindle Total**

1. Spindle motor



2. Tool

3. Tool pan

### 6.2.2 Understanding of Tool Pan

1. Tool fixing and locking bolt

2. Tool

3. Tool jackscrew

4. Tool pan

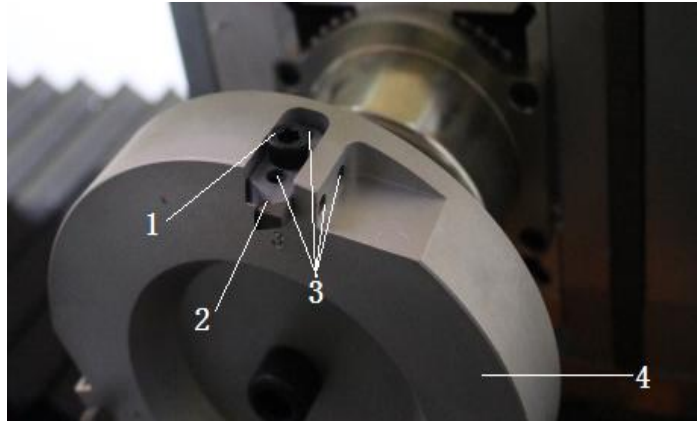

### 6.2.3 Tool

The tool is divided into two types: roughing tool (MY01) and finishing tool (MY02). From the view of shape, the tool edge of the roughing tool is in an integral arc shape; the tool edge of the finishing tool is straight in the middle and in a small arc shape on both sides.



Finishing tool



Roughing tool

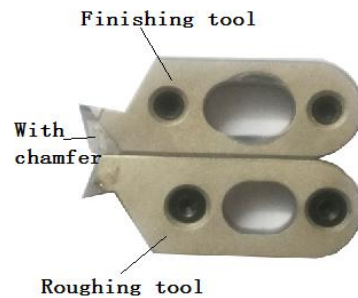

1. Tool
2. Tool upper jackscrew
3. Tool lower jackscrew

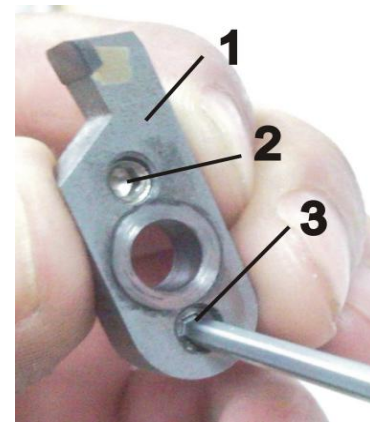

For the alloy tool, it is necessary to adjust the contact angle between the tool and the material to achieve a smooth polishing effect. The function of the upper jackscrew is to adjust the contact angle.

#### 6.2.4 Tool Installation and Adjustment

1. Installation of the tool: the tool is installed and locked on the tool holder. The tool holder is locked on the bayonet of the tool pan. The direction of the tool edge is consistent with the rotation direction (counterclockwise) of the tool pan.

2. The machine is equipped with three-tool pan, namely, two roughing tools and one finishing tool.

As shown below, the roughing tools are installed at two bayonets having long distance from the center of the tool pan. The bayonets where the two bayonets are installed are different, which are defined as roughing tool 1 and roughing tool 2. The finishing tool is installed at the bayonet having shortest distance from the center of the tool pan.

Position relation of three tools: distance from the center of the tool pan: roughing tool 1 > roughing tool 2 > finishing tool.

##### **Method : set the tool through the tool setting device.**

As shown in the figure below, install the tool setting device near the tool to be set on the tool pan. Make the dial indicator in contact with the tool nose of the tool to be set.

1. Adjust the tool height adjustment jackscrew by taking the roughing tool 1 as a benchmark according to the tool installation relation, align the big pointer with zero or turn the dial to make zero coincide with the big pointer, and record the scale of the

small pointer. Lock the roughing tool 1, and remove the tool setting device.

2. Adjust the roughing tool 2, install the tool setting device near the roughing tool 2, adjust the tool height adjustment jackscrew, and make the big pointer of the dial indicator point to 20, namely, 0.2mm. The scale requirements of the small pointer are the same as that recorded in the step 1. Lock the roughing tool 2, and remove the tool setting device.

3. Adjust the finishing tool by following the same steps mentioned above, adjust the tool height adjustment jackscrew, and make the big pointer of the dial indicator point to 25, namely, 0.25mm. The scale requirements of the small pointer are the same as that recorded in the step 1. Lock the finishing tool, and remove the tool setting device.

Height relation of three tools: roughing tool 2 > roughing tool 1: 0.2mm; finishing tool > roughing tool 2: 0.05mm

**Note: when adjusting the three tools, make sure that the scales of the small pointer are the same on the dial indicator.**

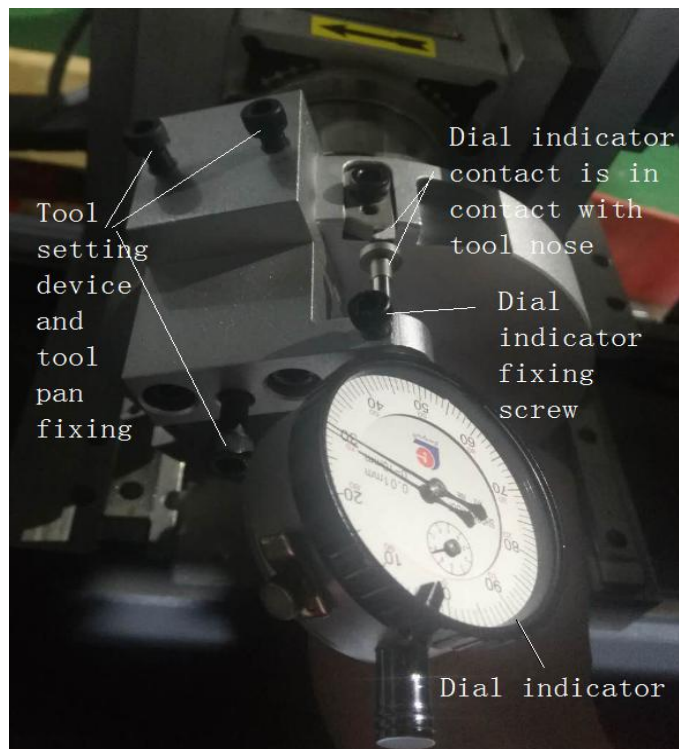

## 5. Gloss adjustment of polished surface

The gloss of the polished surface mainly depends on the finishing angle of the finishing tool. Two upper and lower tool adjustment jackscrews are arranged on the finishing tool. When the polished material cannot achieve the transparent effect and the finishing tool is OK, the tool adjustment jackscrew can be adjusted to achieve the effect. Adjustment method: only adjust the lower jackscrew. The finishing angle of the finishing tool is changed to achieve the transparent effect by adjusting the length of the lower jackscrew exceeding the tool surface. The empirical value is 0.2 to 0.4 that the lower jackscrew extends by. If the effect of the polished material is foggy and dull, it will be necessary to reduce the size as the tool adjustment jackscrew exceeds the tool surface too large. If the effect of the polished material is bright but with tool marks or white marks, it will be necessary to increase the size to the best effect as the tool adjustment jackscrew exceeds the tool surface too small.

## 6. Confirmation of size

After the effect is confirmed, measure the size of a standard material and record it. After polishing, measure the size again. The difference between the two sizes is the cutting depth of the actual single side. If it is unsuitable, adjust the spindle limit setting knob.

(As the edge of the material cut by the cutting machine is relatively rough, it is generally required to have a cutting depth of more than 0.8mm on each side. Please keep enough allowance when cutting.)

# Chapter VII Equipment Operating Procedure

## 7.1 Main Electrical Components

1. Spindle frequency converter
2. Lateral movement frequency converter
3. 24V power supply
4. PLC
5. Power repeater
6. Baffle repeater
7. Spindle repeater
8. Fuse terminal
9. AC contactor
10. Main power switch

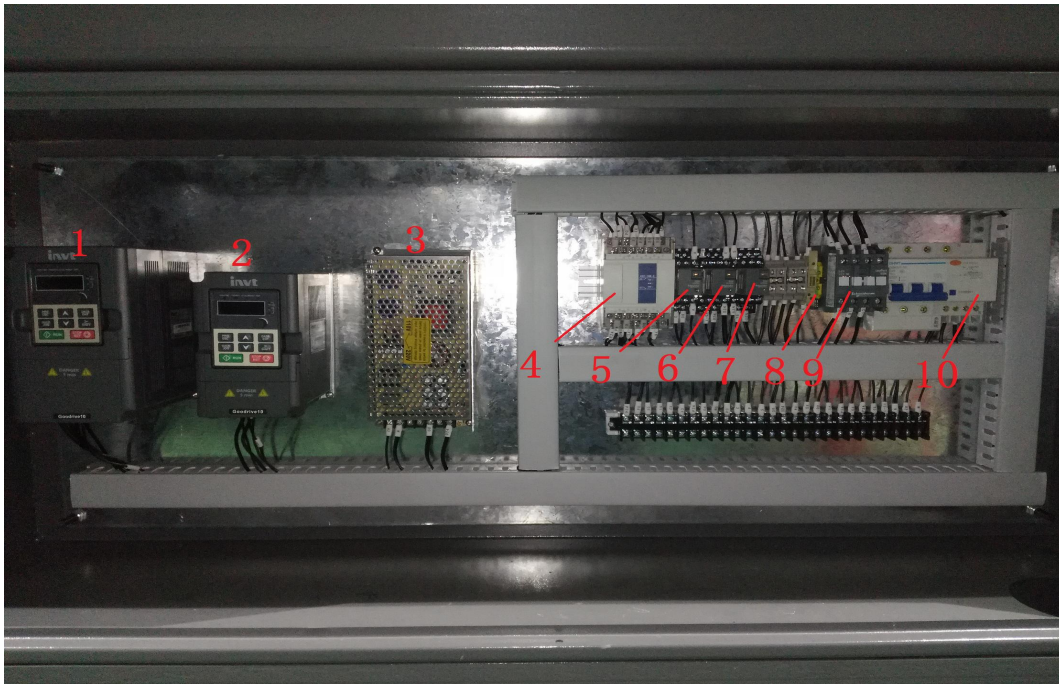

## 7.2 Operating Procedure

### 7.2.1 Operating Procedure Before Running

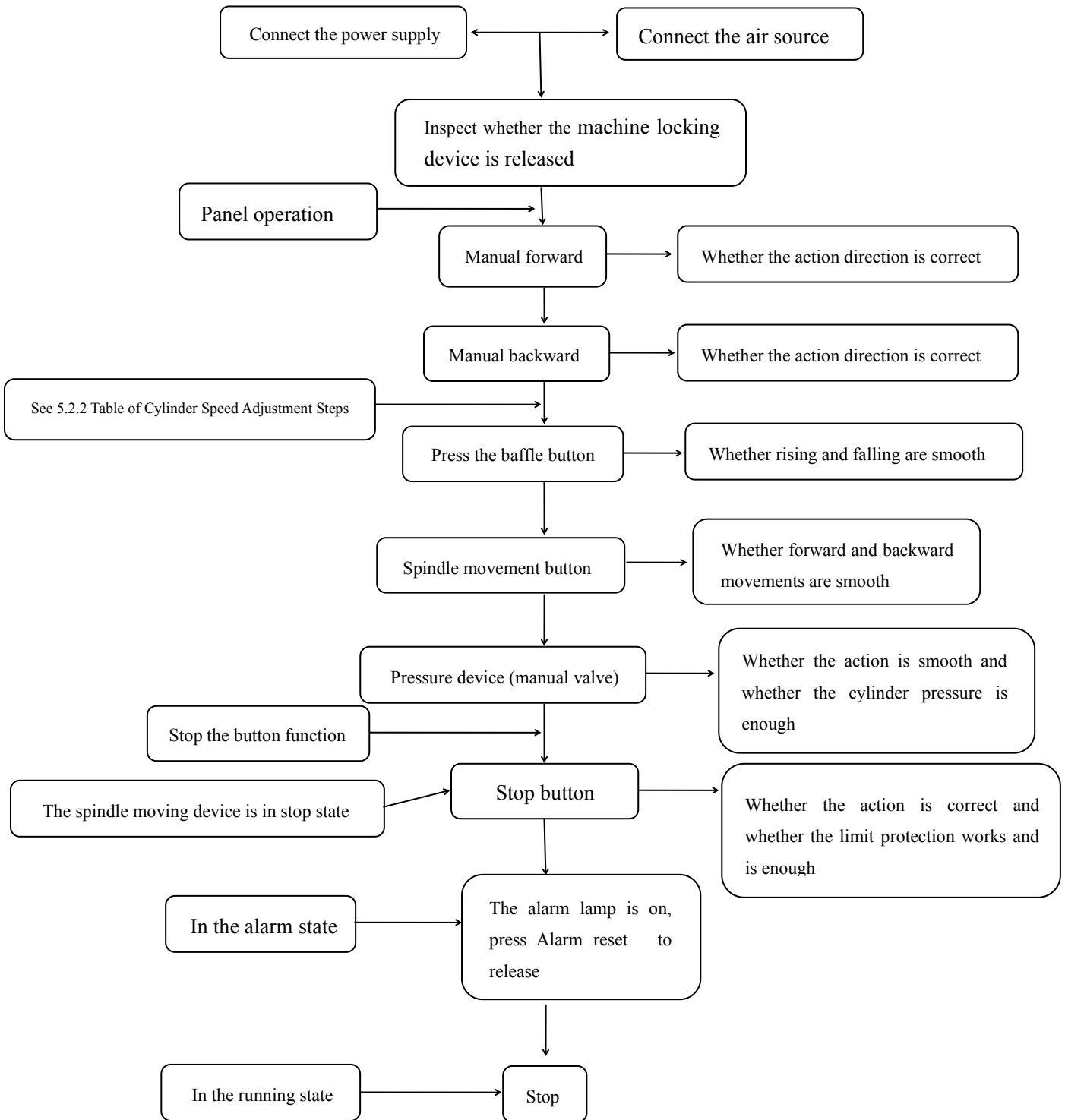

## 7.2.2 Tool Setting Procedure

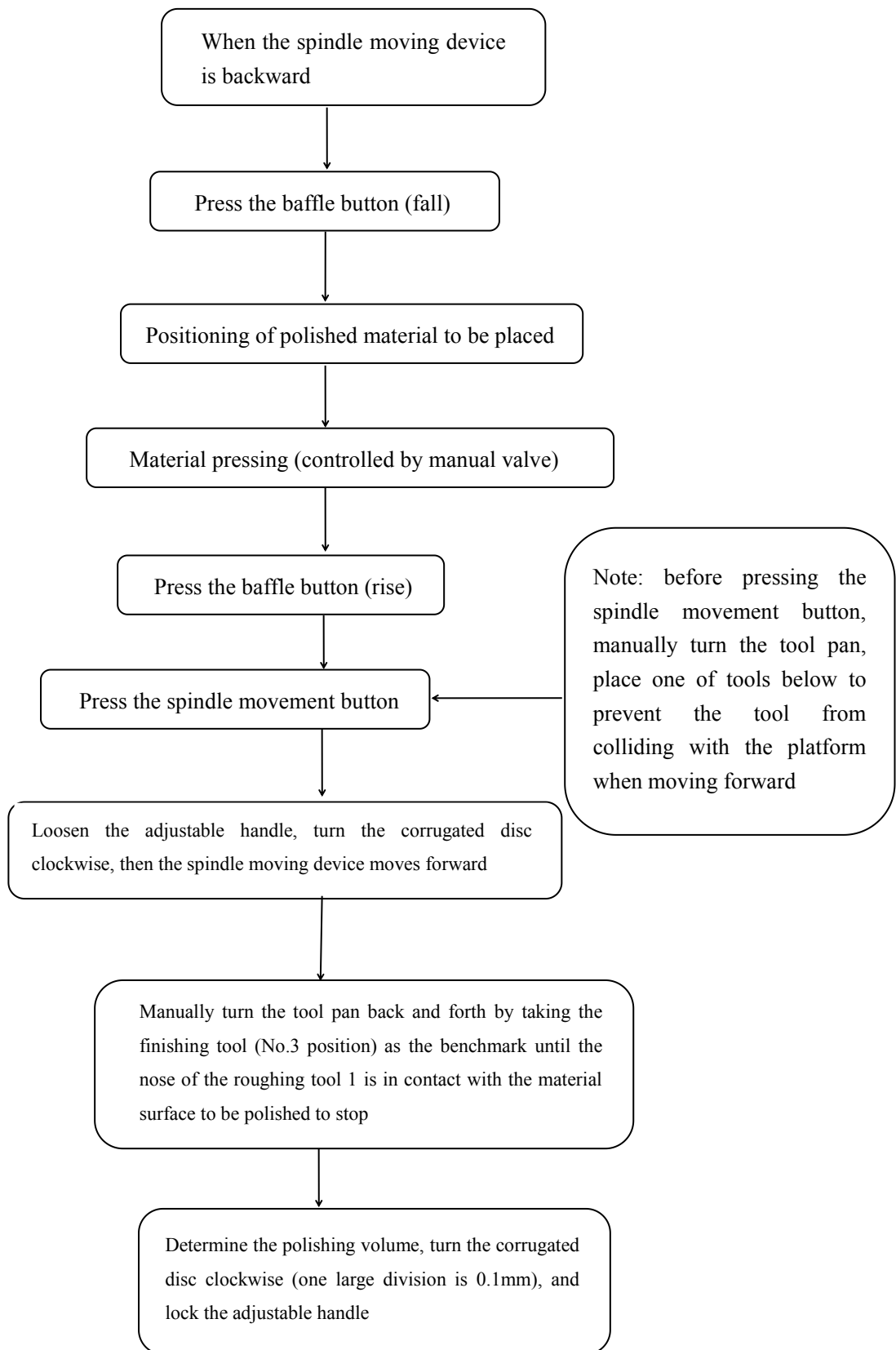

### 7.2.3 Running Procedure

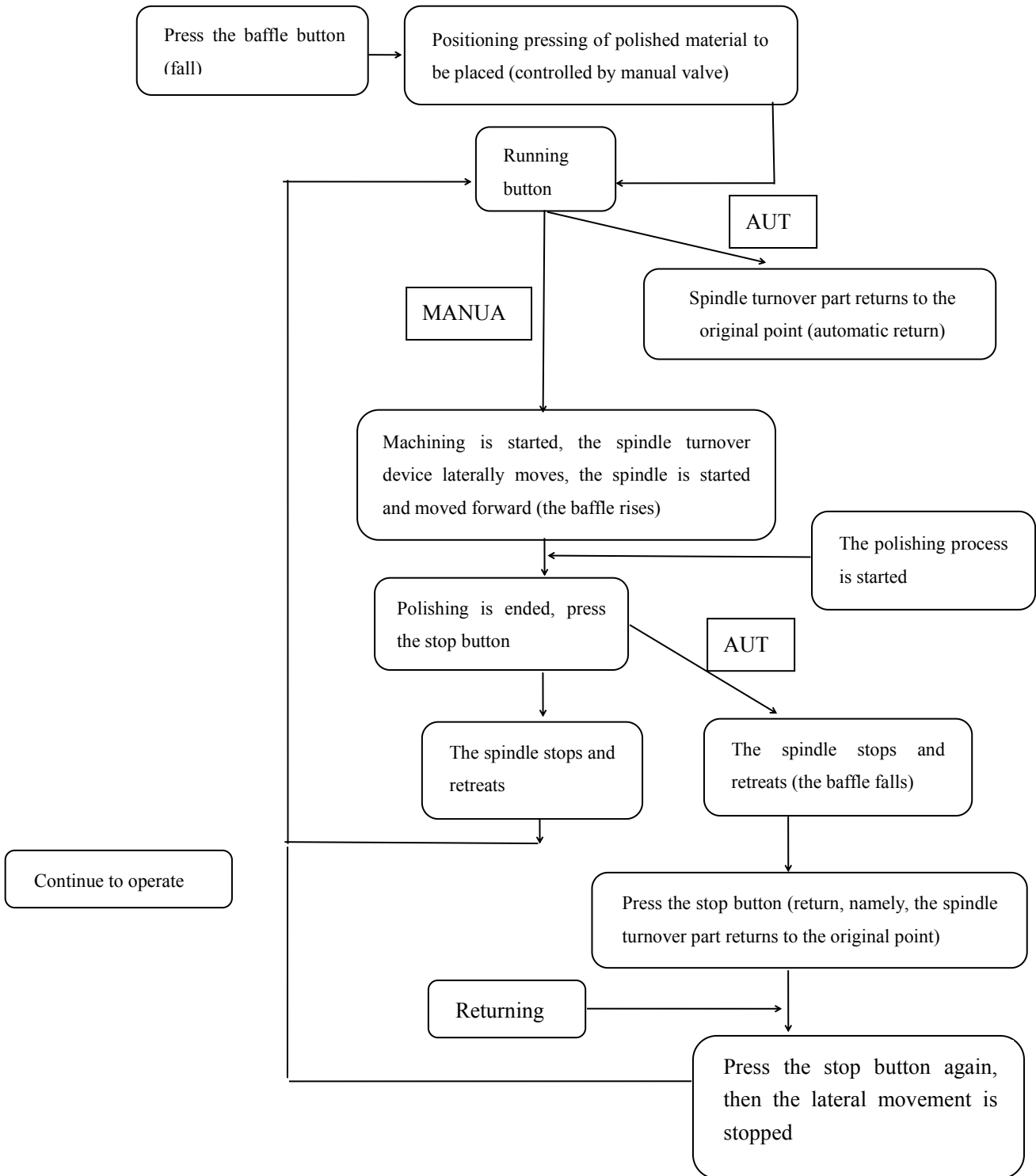

# **Chapter VIII Common Faults and Equipment Maintenance**

## **8.1 Common Faults**

1. The equipment faults mainly comes from the cylinder. If there is air leakage in each joint, it shall be reconnected till no air leakage.

2. If the cylinder has a rebound phenomenon, the inner sealing ring may be worn and shall be replaced.

3. All pneumatic or electrical components shall be repaired or replaced immediately in case of functional failure.

## **8.2 Equipment Maintenance**

1. During duty shifting, inspect whether there is air leakage in each cylinder, and handle it.

2. Clean the equipment environment and the oil stain on the equipment during duty shifting.

3. Weekly add lubricating oil to all guide rails, lead screws and moving parts.

4. Please add light engine oil to the oil filter tube of the oil-water separator to ensure the cylinder life.